

# Spierings

## SK597-AT4

max. Ausladung:	48,00 m
Spitzenlast:	1,70 t
max. Traglast:	7,00 t
max. Hakenhöhe bei Steilstellung:	58,10 m

SPIERINGS SK597-AT4

7 t

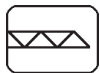

48 m



6,93x7 m



30 t

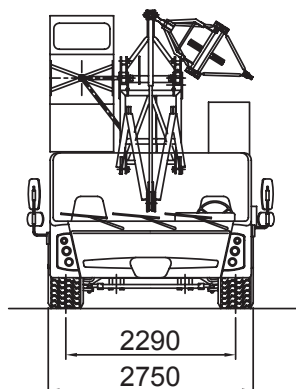
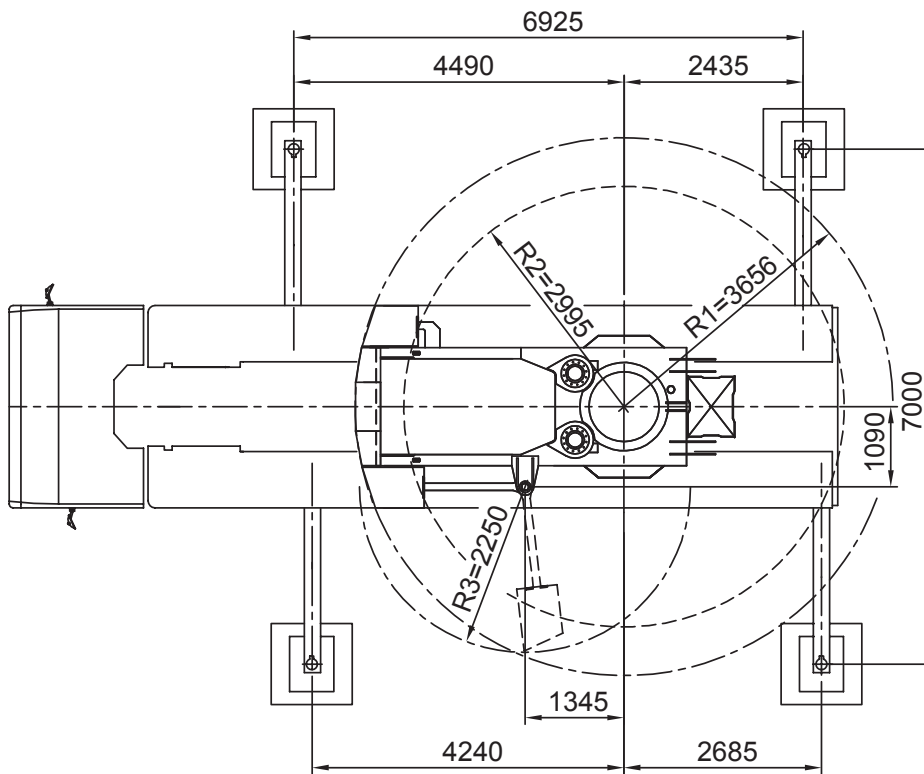
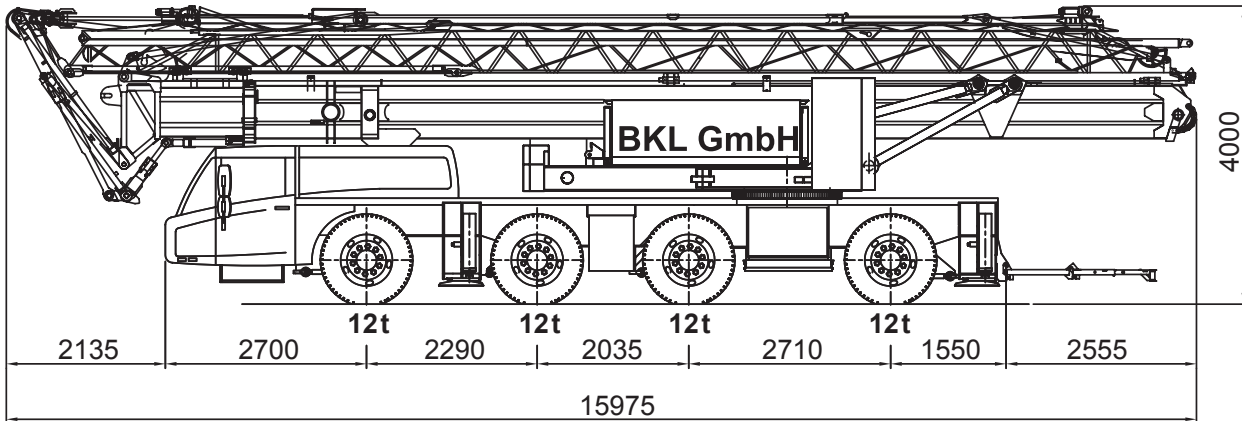

Angaben gemäß Hersteller. Angaben und Informationen ohne Gewähr. Irrtum und Änderung vorbehalten. Haftung ausgeschlossen. September 2022.

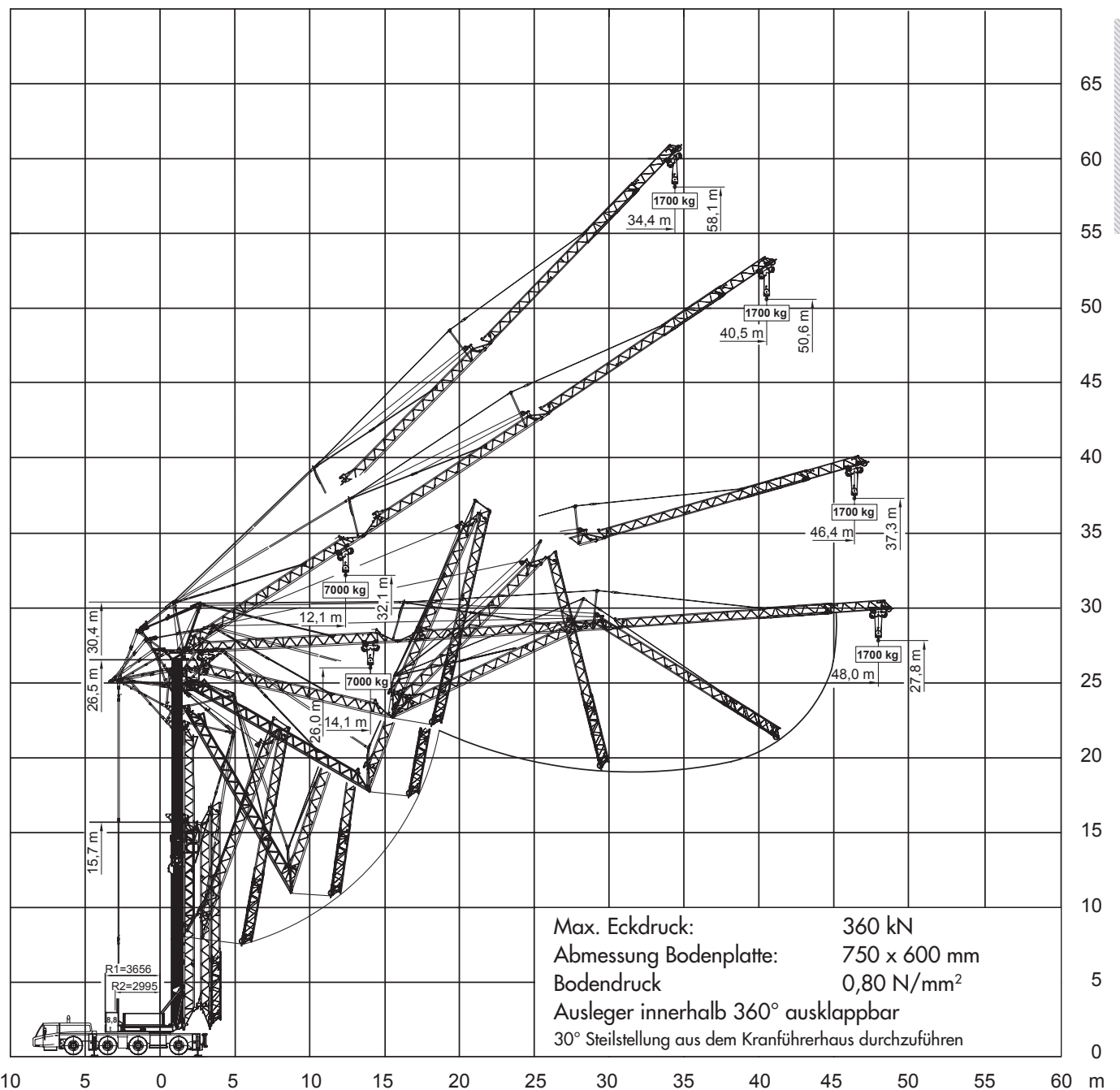

MOBILBAUKRANE

Angaben gemäß Hersteller. Angaben und Informationen ohne Gewähr. Irrtum und Änderung vorbehalten. Haftung ausgeschlossen. September 2022.

**SPIERINGS SK597-AT4**
**7 t**

48 m



8,8 t



6,93x7 m



360°



75 %

m	48				m
	0°	15°	30°	45°	
3,5	7	1,7	7	1,7	3,5
11	7	1,7	7	1,7	11
12,4	7	1,7	7	1,7	12,4
13	7	1,7	6,615	1,7	13
14	7	1,7	6,06	1,7	14
15	6,495	1,7	5,59	1,7	15
16	6,025	1,7	5,185	1,7	16
17	5,615	1,7	4,83	1,7	17
18	5,26	1,7	4,525	1,7	18
19	4,945	1,7	4,25	1,7	19
20	4,66	1,7	4,005	1,7	20
21	4,41	1,7	3,785	1,7	21
22	4,18	1,7	3,585	1,7	22
23	3,975	1,7	3,41	1,7	23
24	3,785	1,7	3,245	1,7	24
25	3,615	1,7	3,095	1,7	25
26	3,455	1,7	2,96	1,7	26
27	3,31	1,7	2,835	1,7	27
28	3,175	1,7	2,715	1,7	28
29	3,05	1,7	2,61	1,7	29
30	2,935	1,7	2,505	1,7	30
31	2,825	1,7	2,415	1,7	31
32	2,725	1,7	2,325	1,7	32
33	2,63	1,7	2,245	1,7	33
34	2,54	1,7	2,165	1,7	34
35	2,455	1,7	2,095		35
36	2,38	1,7	2,025		36
37	2,305	1,7	1,965		37
38	2,235	1,7	1,9		38
39	2,17	1,7	1,845		39
40	2,105	1,7	1,79		40
41	2,045	1,7	1,74		41
42	1,99	1,7	1,7		42
43	1,945	1,7			43
44	1,9	1,7			44
45	1,835	1,7			45
46	1,79	1,7			46
47	1,74				47
48	1,7				48

Angaben gemäß Hersteller. Angaben und Informationen ohne Gewähr. Irrtum und Änderung vorbehalten. Haftung ausgeschlossen. September 2022.

SPIERINGS SK597-AT4

7 t



48 m



8,8 t



6,93x5,85 m



360°



75 %

m	48				m
	0°	15°	30°	45°	
3,5	7	1,2	7	1,2	3,5
9	7	1,2	7	1,2	9
10	7	1,2	6,675	1,2	10
11	6,895	1,2	5,935	1,2	11
12	6,205	1,2	5,34	1,2	12
13	5,64	1,2	4,85	1,2	13
14	5,165	1,2	4,44	1,2	14
15	4,76	1,2	4,09	1,2	15
16	4,415	1,2	3,79	1,2	16
17	4,11	1,2	3,525	1,2	17
18	3,845	1,2	3,295	1,2	18
19	3,61	1,2	3,095	1,2	19
20	3,4	1,2	2,91	1,2	20
21	3,21	1,2	2,75	1,2	21
22	3,04	1,2	2,6	1,2	22
23	2,89	1,2	2,47	1,2	23
24	2,75	1,2	2,35	1,2	24
25	2,62	1,2	2,235	1,2	25
26	2,505	1,2	2,135	1,2	26
27	2,395	1,2	2,04	1,2	27
28	2,295	1,2	1,955	1,2	28
29	2,2	1,2	1,875	1,2	29
30	2,115	1,2	1,8	1,2	30
31	2,035	1,2	1,73	1,2	31
32	1,96	1,2	1,665	1,2	32
33	1,89	1,2	1,605	1,2	33
34	1,825	1,2	1,545	1,2	34
35	1,765	1,2	1,495		35
36	1,705	1,2	1,445		36
37	1,65	1,2	1,395		37
38	1,595	1,2	1,35		38
39	1,55	1,2	1,31		39
40	1,5	1,2	1,265		40
41	1,455	1,2	1,23		41
42	1,415	1,2	1,2		42
43	1,375	1,2			43
44	1,34	1,2			44
45	1,3	1,2			45
46	1,265	1,2			46
47	1,23				47
48	1,2				48

MOBILBAUKRANE

Angaben gemäß Hersteller. Angaben und Informationen ohne Gewähr. Irrtum und Änderung vorbehalten. Haftung ausgeschlossen. September 2022.